

Towing hitch equipment:

| | | | |
|------------------------------------|--|--|---|
| Pos. 1 Main bar PCS.: 1 | Pos. 5 Left bracket PCS.: 1 | Pos. 10 Bolt 8,8 B M12x25mm PCS.: 6 | Pos. 16 Plain washer Ø13mm PCS.: 18 |
| Pos. 2 Tow ball PCS.: 1 | Pos. 6 Right channel section PCS.: 1 | Pos. 11 Bolt 8,8 B M10x30mm PCS.: 1 | Pos. 17 Plain washer Ø10.5mm PCS.: 1 |
| Pos. 3 Socket plate PCS.: 1 | Pos. 7 Left channel section PCS.: 1 | Pos. 12 Nut 8 B M16 PCS.: 2 | Pos. 18 Spring washer Ø16.3mm PCS.: 2 |
| Pos. 4 Right bracket PCS.: 1 | Pos. 8 Bolt 8,8 B M16x50mm PCS.: 2 | Pos. 13 Nut 8 B M12 PCS.: 10 | Pos. 19 Spring washer Ø12.2mm PCS.: 18 |
| | Pos. 9 Bolt 8,8 B M12x40mm PCS.: 12 | Pos. 14 Nut 8 B M10 PCS.: 1 | Pos. 20 Spring washer Ø10.2mm PCS.: 1 |
| | | Pos. 15 Plain washer Ø17mm PCS.: 2 | Pos. 21 Ball cover PCS.: 1 |



PPUH AUTO-HAK Sp.J.

Produkcja Zaczepów Kulowych
Henryk & Zbigniew Nejman
76-200 SŁUPSK ul. Słoneczna 16K
tel/fax (059) 8-414-414; 8-414-413
E-mail: office@autohak.com.pl
www.autohak.com.pl

Towing hitch (without electrical set)

Class: **A50-X** Cat. no. **R29**

Designed for:

Manufacturer: **FIAT**

Model: **IVECO DAILY 35C/50C**

Type: **metal built-up,**

loading platform, with step

produced since 05.1999 till 12.2013

Technical data:

D-value: 20,52 kN

maximum trailer weight: **3500 kg**

maximum vertical cup mass: **100 kg**

Approval number acc. to regulations EKG/ONZ 55.01: **E20-55R-01 1802**

Foreword

This towing hitch is designed according to rules of safety traffic regulations. The towing hitch is a safety component and can be install only by qualified personnel. Any alteration or conversion of the towing hitch is prohibited and would lead to cancellation of design certification. Remove insulating compound and underseal from vehicle (if present) in the area of the matting surfaces of the towing hitch. The vehicle manufacturer's specifications regarding trailer mass and max. vertical cup mass are decisive for driving whereat values for the towing hitch cannot be exceeded.

D-value formula:

$$\frac{\text{Max trailer weight [kg]} \times \text{Max vehicle weight [kg]}}{\text{Max trailer weight [kg]} + \text{Max vehicle weight [kg]}} \times \frac{9,81}{1000} = D \text{ [kN]}$$

FITTING INSTRUCTION

| Clamp mark in acc. with | | Cables joining |
|-------------------------|-----|---------------------------|
| ISO | PN | |
| 1 | L | Left directional lights |
| 2 | + | Rear fog lights |
| 3 | 31 | Ground |
| 4 | R | Right directional lights |
| 5 | 58R | Right side parking lights |
| 6 | 54 | Stoplights |
| 7 | 58L | Left side parking lights |

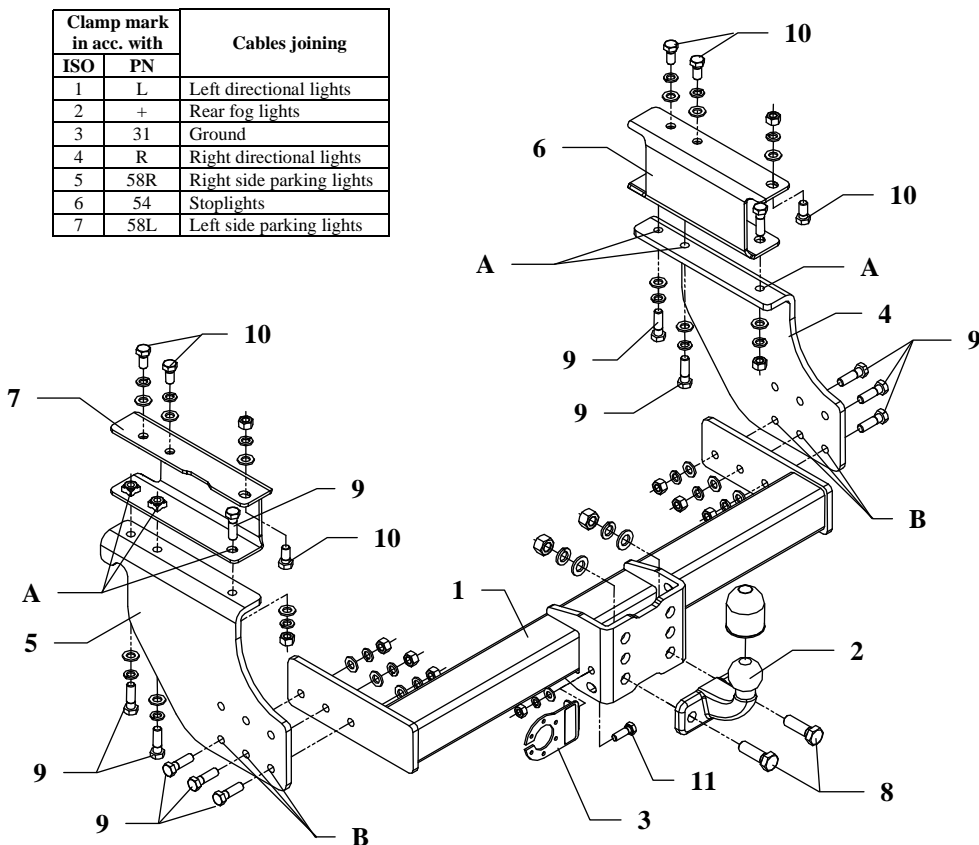

This towing hitch is designed to assembly in following cars:
FIAT IVECO DAILY 35C/50C, metal built-up, loading platform, with step, produced since 05.1999 till 12.2013, catalogue no. **R29** and is prepared to tow trailers max total weight up to **3500 kg** and max vertical mass **100 kg**.

From manufacturer

Thank you for buying our product. Their reliability has been confirmed in many tests. Reliability of towing hitch depends also on correct assembly and right operation. For this reasons we kindly ask to read carefully this instruction and apply to hints.

The towing hitch should be installing in points described by a car producer.

The instruction of the assembly

1. Channel sections (pos. 6 and 7) put on the left and right side of chassis members in this way, so holes A in elements 6 and 7 agree with original holes in the members.
2. Side brackets (pos. 4 and 5) put from below to the frame and through holes A, existing holes (in chassis) and holes in elements (pos. 6 and 7) fix all using bolts M12x40mm (pos. 9).
3. Main bar of the towing hitch (pos. 1) fix using bolts M12x40mm (pos. 9) through holes B to mounted brackets (pos. 4 and 5).
4. Fix tow-ball (pos. 2) using bolts M16x50mm (pos. 8) from accessories.
5. Fix socket plate (pos. 3) using bolt M10x30mm (pos. 11).
6. Tighten all bolts according to the torque shown in the table.
7. Connect electric wires of 7-poles socket according to the instruction of the car. (Recommend to make at authorized service station).
8. Complete paint layer damaged during installation.

Torque settings for nuts and bolts (8,8):

| | | |
|--------------------|---------------------|---------------------|
| M6 - 11 Nm | M8 - 25 Nm | M10 - 50 Nm |
| M12 - 87 Nm | M14 - 138 Nm | M16 - 210 Nm |

NOTE

After install the towing hitch you should get adequate note in registration book (at authorised service station). The car should be equipped with:

- Indicators
- Tow mirrors

Check all bolts and nuts after 1000km of exploitations. The ball of towing hitch must be always kept clear and conserve with a grease.