

# bosal

**Инструкция по монтажу  
тягово-цепного устройства  
шарового типа 3307 А  
для автомобилей  
GREAT WALL  
HOVER**

	2010 -...
	1500
	75
	23



462800,

« - »

18

т. (35363) 7-05-06

факс: (35363) 7-13-20

т. (495) 785-66-07

[www.bosal-autoflex.ru](http://www.bosal-autoflex.ru)

« - »:	(8182) 22-48-15
"	8(8442) 98-74-98
"	8(343) 379-39-89, 373-42-73
"	8(343) 26-88-308
"	8(3952) 710-194
"	8(495) 777-54-59
"	8(495)745-79-11
"	8(495) 788-95-97
"	8(495) 720-51-03
"	8(3532) 57-99-85
"	8-905-899-5012
"	8(383) 291-59-60
"	8(831) 279-53-24
"	8(3422) 98-27-20
"	8(342) 220-87-87
"	8-927-002-90-06
"	8(3462) 24-00-44
"	8(3842) 21-14-76
"	8-902-940-4151
"	8(3452) 32-22-12, 41-52-62
"	8-961-213-0278
"	8-917-347-1700
"	8(351) 269-44-75, 900-72-73
"	8(3512) 773-76-91

41.55-2005.

• Ø13 « » « »  
 • « » Ø18 « »  
 • 2  
 • 56 , 2  
 ( . )

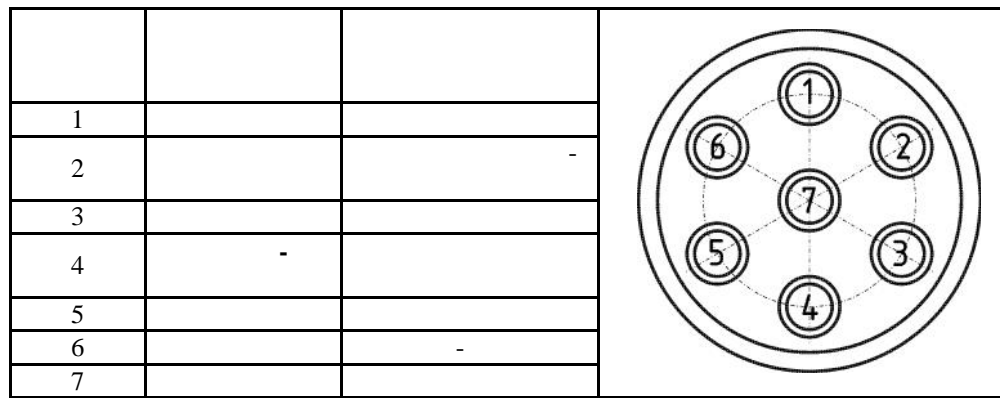
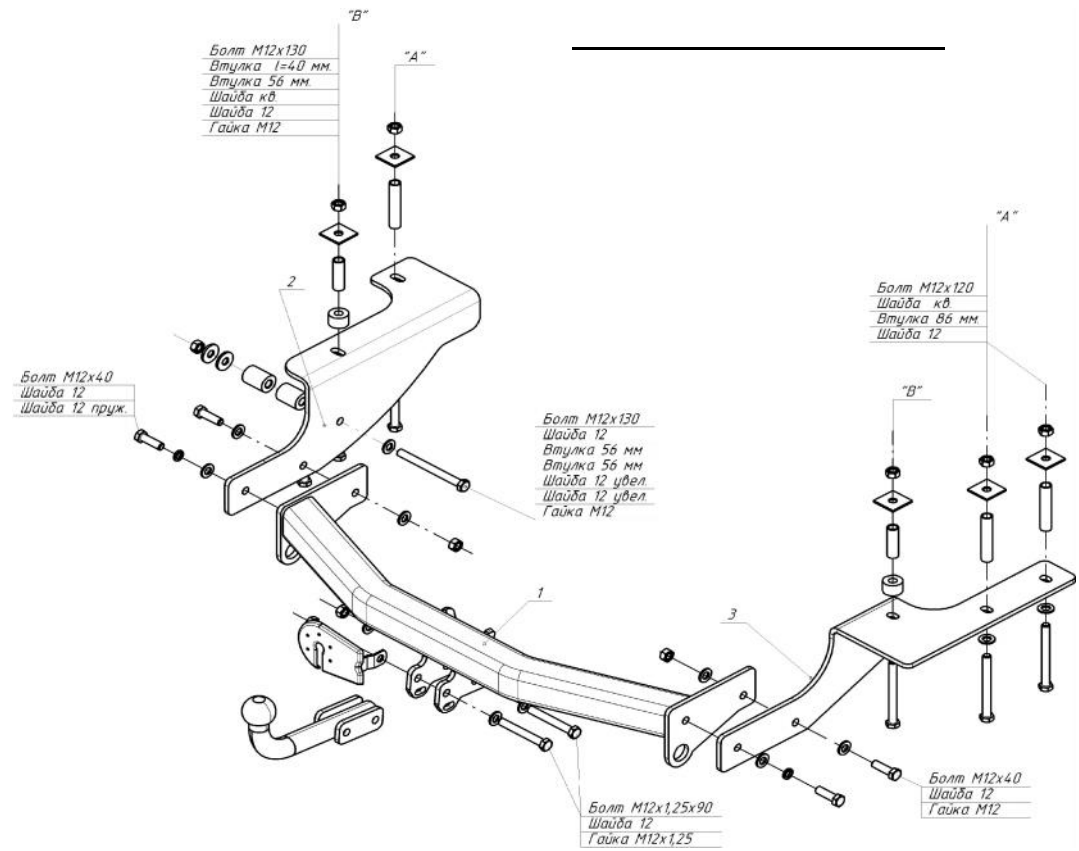

	1
	1
	1
	1
	1
	1

Схема обрезки кабеля

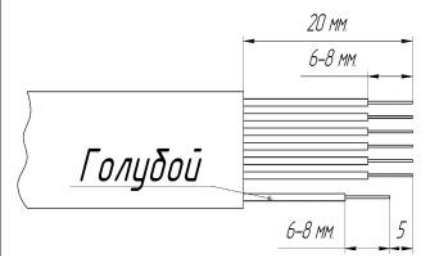

12 40	4
12 1,25 90	2
12 120	3
12 130	3
12	8
12 1,25	2
12	2
12	16
12	2
40 40 3	6
86	3
56	2
Ø13 Ø30 l=40	4
	2
VH 0804	1
	1
	1
	1
190	1
	3
	1