

bosal

**Инструкция
по монтажу тягово-сцепного
устройства шарового типа 2182 F
для автомобилей
VW Transporter T5**

	2003 -...
	2000
	100
	17,6



462800,

« - »

18

./ : (35363) 7-05-06

./ : (35363) 7-13-20

(495) 785-66-07

www.bosal-autoflex.ru

« - »:	(8182) 22-48-15
" - "	" 8(8442) 98-74-98
" - "	" 8(343) 379-39-89, 373-42-73
" - "	" 8(343) 26-88-308
" - "	" 8(3952) 710-194
" - "	" 8(495) 777-54-59
" - "	" 8(495)745-79-11
" - "	" 8(495) 788-95-97
" - "	" 8(495) 720-51-03
" - "	" 8(3532) 57-99-85
" - "	" 8-905-899-5012
" - "	" 8(383) 291-59-60
" - "	" 8(831) 279-53-24
" - "	" 8(3422) 98-27-20
" - "	" 8(342) 220-87-87
" - "	" 8-927-002-90-06
" - "	" 8(3462) 24-00-44
" - "	" 8(3842) 21-14-76
" - "	" 8-902-940-4151
" - "	" 8(3452) 32-22-12, 41-52-62
" - "	" 8-961-213-0278
" - "	" 8-917-347-1700
" - "	" 8(351) 269-44-75, 900-72-73
" - "	" 8(3512) 773-76-91

..... :

..... VIN

.....

.....

41.55-2005.

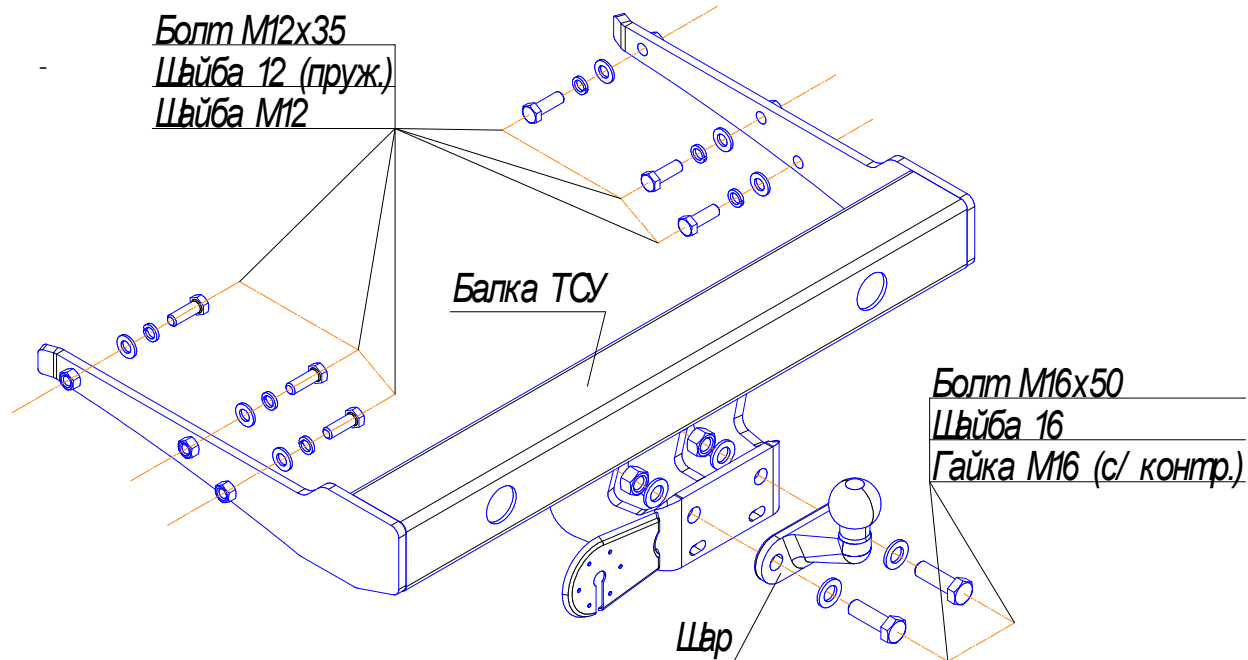

12 = 79 Nm, 16 = 195 Nm.

1			
2			
3			
4			
5			
6			

	1 .
	1 .
	1 .

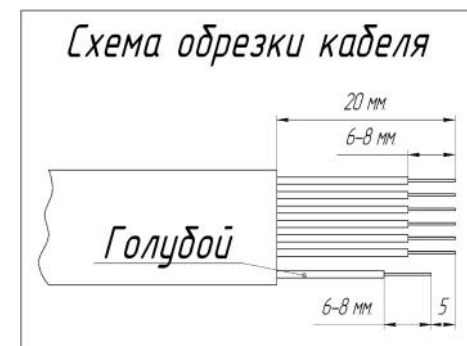

16 50	2 .
12 35	6 .
16 /	2 .
16	4 .
12 (.)	6 .
12	6 .
4 30	3 .
4	3 .
4	3 .
4 (.)	3 .
F	1 .
	1 .
	1 .
190	1 .
	1 .