



06/10-

VOLVO S60

Cat. No. **V/033**

E20

E20 55R-01 5075

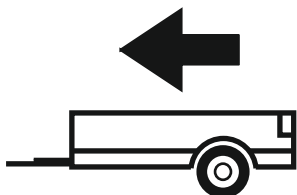

1950kg

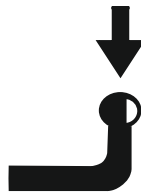

90kg

D=10,80kN

D (kN) =



MAX kg x MAX kg

x 0,00981



MAX kg + MAX kg

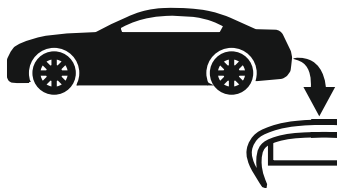

IMIOLA HAK-POL

96-111 KOWIESY, CHOJNATA 23A, POLAND

Tel. + 48 46 831 73 31, fax +48 831 74 29

e-mail: office@imiola.pl, www.imiola.pl



PRZEKRÓJ A-A

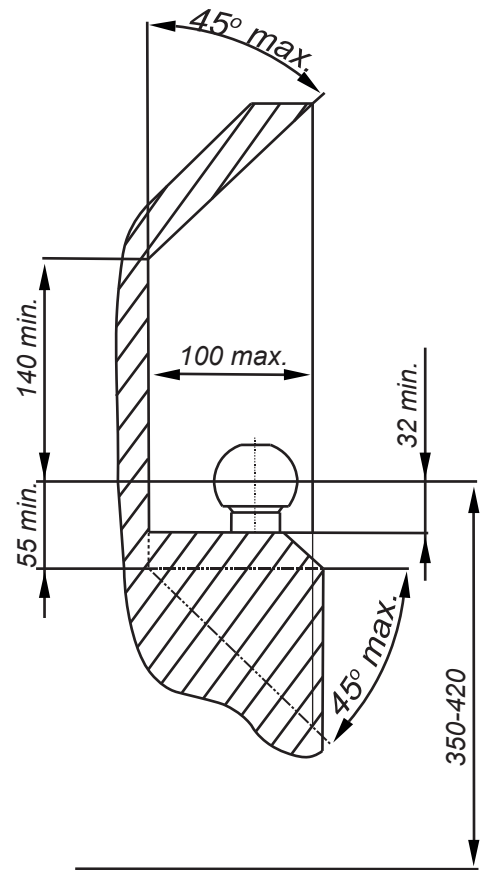

PL Należy zagwarantować przestrzeń swobodną według załącznika VII, rysunek 25a/b Regulaminu EKG ONZ 55.01 przy dopuszczalnym ciężarze całkowitym pojazdu.

F L'espace libre doit être garanti conformément à l'annexe VII, illustration de la réglementation 55.01 CE pour un poids total en charge autorisé du véhicule.

GB The clearance specified in appendix VII, diagram 25a/b of Regulation No. 55.01 UN EU must be guaranteed at laden weight of the vehicle.

D Der Freiraum nach Anhang VII, Abbildung 25a/b der Vorschriften 55.01 EG ist zu gew 25a/bahrleisten bei zulässigem Gesamtgewicht des Fahrzeuges.

Moment skręcający dla śrub i nakrętek (8.8) Torque settings for nuts and bolts (8.8)	
M8	25Nm
M10	55Nm
M12	85Nm
M14	135Nm
M16	195Nm









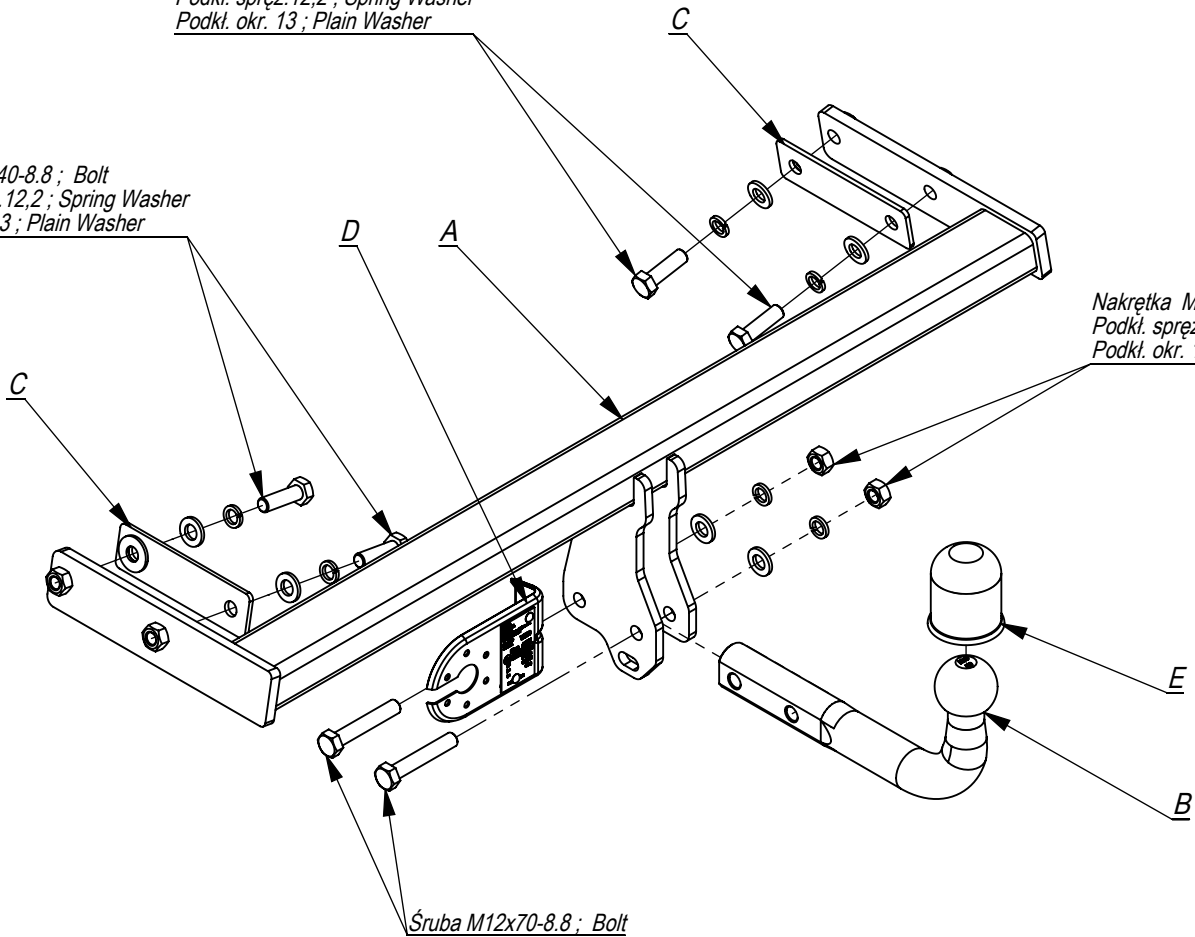

Śruba M12x40-8.8 ; Bolt
 Podkł. spręż. 12,2 ; Spring Washer
 Podkł. okr. 13 ; Plain Washer

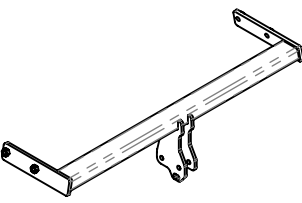
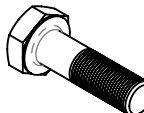
Śruba M12x40-8.8 ; Bolt
 Podkł. spręż. 12,2 ; Spring Washer
 Podkł. okr. 13 ; Plain Washer

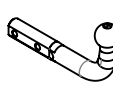
Nakrętka M12 ; Nut
 Podkł. spręż. 12,2 ; Spring Washer
 Podkł. okr. 13 ; Plain Washer

Śruba M12x70-8.8 ; Bolt



	A	x1		M12x70	2
				M12x40	4
	B	x1		M12	2
	C	x2		13	6
	D	x1		12,2	6
	E	x1			

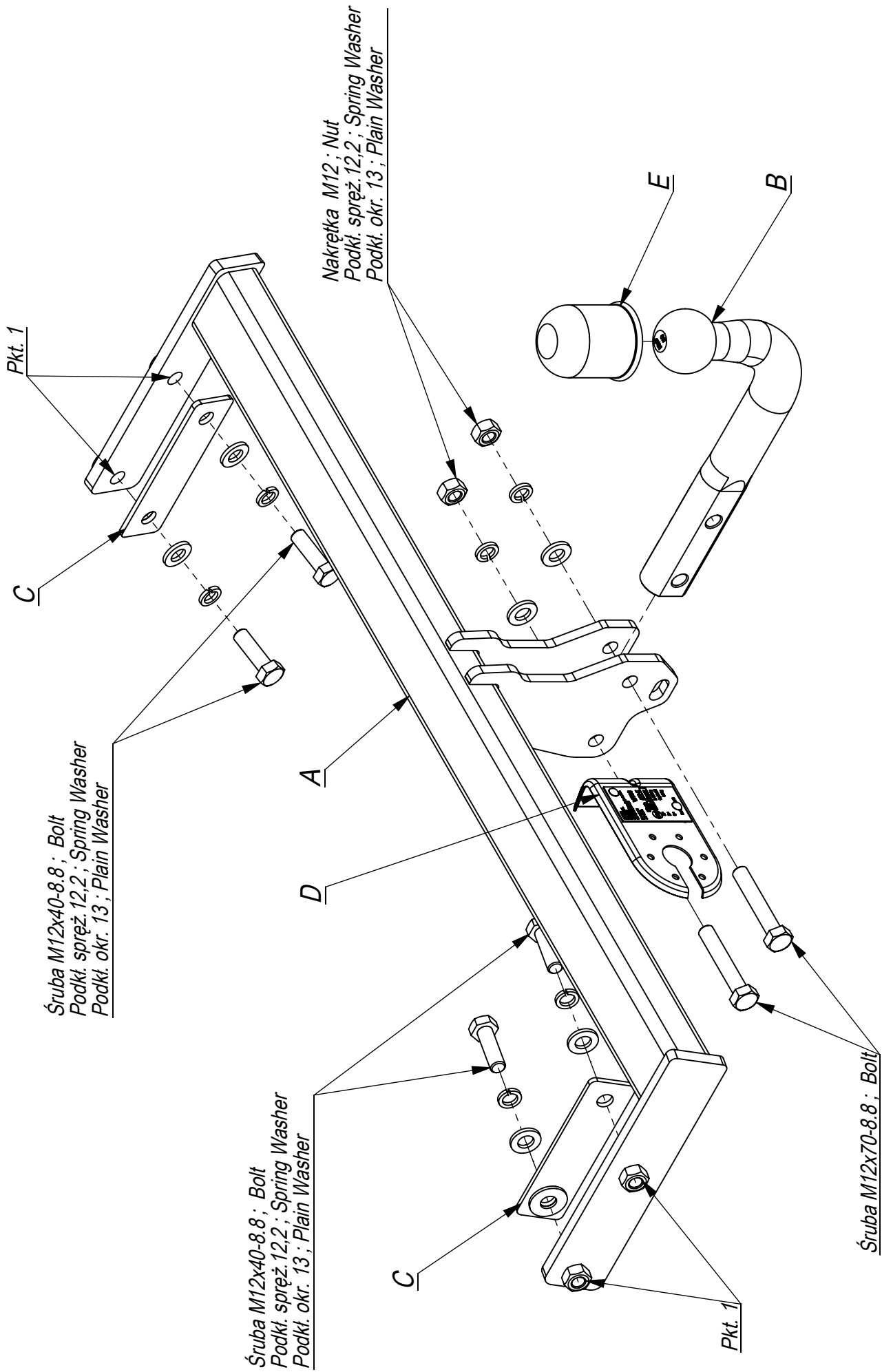

Śruba M12x40-8.8 ; Bolt
 Podkł. spręż. 12,2 ; Spring Washer
 Podkł. okr. 13 ; Plain Washer

Śruba M12x40-8.8 ; Bolt
 Podkł. spręż. 12,2 ; Spring Washer
 Podkł. okr. 13 ; Plain Washer

Nakrętka M12 ; Nut
 Podkł. spręż. 12,2 ; Spring Washer
 Podkł. okr. 13 ; Plain Washer

Śruba M12x70-8.8 ; Bolt

Nr katalogowy	Volvo S60	od 06/10 ->
V/033	Volvo V60	od 11/10 ->
Marka		

- Odkręcić zderzak .
- Od tylnego pasa samochodu odkręcić belkę zderzeniową (nie będzie już wykorzystana).
- W otwory podłużnic wsunąć belkę zaczepu A i poprzez technologiczne otwory w podłużnicy skręcić śrubami M12x40 8.8 (pkt 1) stosując nakładki C.
- Dokręcić wszystkie śruby z momentem wg tabeli.
- Wykonać wycięcie w dolnej części zderzaka na gniazdo i uchwyt kuli.
- Zamontować zderzak.
- Przykręcić kulę i blachę gniazda elektrycznego śrubami M12x70 8.8 (pkt 2).
- Podłączyć instalację elektryczną.

- Unscrew the bumper.
- Unscrew the bumper bar from the rear belt of the car (it will not be used any more).
- Insert the main bar A in the holes of frame side members and screw through the technological holes in the frame side members with bolts M12x40 8.8 (point 1) using the plates C.
- Tighten all the bolts according to the torque setting -see the table.
- Cut out the fragment in the lower part of bumper to fit the handles of towball.
- Assemble the bumper.
- Fix the ball and electric plate with bolts M12x70 8.8 (point 2).
- Connect the electric wires.

- Dévisser le pare-chocs.
- Dévisser la poutre pare-chocs de la jupe arriere de la voiture (elle ne sera plus utilisée).
- Glisser la barre d'attelage A dans les orifices des longerons et a travers les trous technologiques dans le longeron, l'assembler avec des boulons M12x40 8.8 (pt 1) en utilisant les protections C.
- Serrer tous les boulons avec un couple de serrage selon tableau.
- Exécuter une encoche dans la partie inférieure du pare-chocs, pour la prise et l'encastrement de la boule.
- Installer le pare-chocs.
- Serrer la boule et la tôle de la prise électrique avec les boulons M12x70 8.8 (pt 2).
- Brancher l'installation électrique.

- Den Stoßfänger abschrauben.
- Den Stoßträger abschrauben (wird nicht mehr benötigt).
- Den AHK-Querträger in die Längsträger durch die Öffnungen einschieben und mit Schrauben M12x40 8.8 (Punkt 1) mit dem Element C verschrauben.
- In der Stoßstange einen Ausschnitt für die Klappen der Kugel ausführen.
- Den Stoßfänger einsetzen.
- Schrauben Sie die Kugel und den Steckdosenblech mit den Schrauben M12x70 8.8 an.
- Ziehen Sie alle Schrauben mit dem Drehmoment gemäß der Tabelle an.
- Die Elektroinstallation anschließen. Die elektrische Installation anschließen.

- Desenrosque el parachoques.
- Desenrosque las barra de parachoques. (no se usarán).
- Inserte los elementos de la captura C y D en los largueros y fíjelos con los pernos M12x40 8.8 (punto 1) utilizando la Element C.
- Hacer un corte en el parachoques para las garras de la bola.
- Montar el parachoques.
- Atornille la bola y la placa de toma de corriente eléctrica. con tornillos M12x70 8.8.
- Apretar todos los tornillos con el par según la tabla anterior.
- Conecte la instalación eléctrica.

